



AHP-1200CPV for Cascades Product Manual 9-35EB-1-CAS

Volume 1.3



tecca

Table of Contents

Page	Description
1	Cover Page
2	Left Intentionally Blank
3	Table of Contents
4	AHP-1200CPV with cascade
5	What's in the Boxes?
6	How do I install the cover?
7	What are these other things?
8	How do I set this up to use it?
9	Cascade installation
10	CCP-22 & CCP-31 Installation drawing SK080710
11	CCP-21 Installation drawing SK080710
12	Safety Features and Standards
13	Warnings
14	How do I use it ?? NOW !!
16	Front Panel Layout
17	Physical Layout
18	Adjusting the Set Point Temperature
17	Initiating Tune to Set Point
18	Changing from degrees C to F
19	Over-Temperature Safety
19	Adaptive Fan Control
20	Using the external sensor
20	Guaranteed Soak and Ramp Tracking Limits
21	Controller Modes – Entry Method & Passwords
22	Basic Operator Mode, Normal day to day operation
23	Programming Mode
24	Example Profile
25	Ramp/Soak program codes
26	Notes
27	Back Page

AHP-1200CPV

Cooling and Heating Plate for Cascades

Shown with CCP-21 Cascade Installed



What's in the Boxes ???



AHP-1200CPV
Cold/Warm Plate

Power Cord

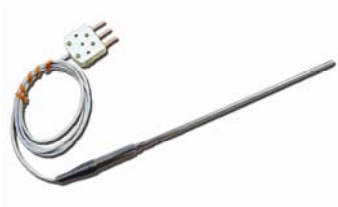

Remote RTD Probe

Hinged Cover



Software
and
Manuals

AHP-1200CPV Product Manual and EasyLog Product Manual in print and CD, TECA EasyLog software, DotNet Framework, iTools Engineering Studio, iTools driver, Sample ramp/soak programs, TECA TC-4300 Operations Manual, AHP-1200CPV Literature

How do I install the cover ???

If test or sample leads are needed in the cold plate area remove these plugs and thread the wires through the hole(s)

1) Unscrew and remove these four screws

2) Install CH-1200 with included four screws and star washers

INFORMATION DISCLOSED HEREIN IS THE CONFIDENTIAL PROPERTY OF TERA CORP. RECEIPT SHALL NOT USE THE INFORMATION IN ANY UNAUTHORIZED MANNER.		USE THIS DIMENSION UNLESS OTHERWISE SPECIFIED IN INCHES. TOLERANCES ARE:		THERMAL ELECTRONIC EQUIPMENT ASSEMBLY CORP.	
DIMENSIONS ARE:		DIMENSIONS ARE:		CH-1200	
DIMENSIONS ARE:		DIMENSIONS ARE:		AHP-1200CPV COVER AND HINGE	
DIMENSIONS ARE:		DIMENSIONS ARE:		INSTALLATION	
DIMENSIONS ARE:		DIMENSIONS ARE:		DRAWN BY: AA	
DIMENSIONS ARE:		DIMENSIONS ARE:		DATE: 01/08/09	
DIMENSIONS ARE:		DIMENSIONS ARE:		REV. NO.: J-4736	
DIMENSIONS ARE:		DIMENSIONS ARE:		MATERIAL: SK090107	
DIMENSIONS ARE:		DIMENSIONS ARE:		PART NO.: SK090105	
DIMENSIONS ARE:		DIMENSIONS ARE:		REV. LEVEL:	
DIMENSIONS ARE:		DIMENSIONS ARE:		PART:	
REV	DESCRIPTION	DATE	APPROVED		

What are these other things ???

CCP-21
Small second stage



CCP-22
Large 2nd stage

CCP-31
2nd and 3rd stage



CC-1200
Cascade Control

Thermally Conductive
Interface Material

How do I set this up to use it?

General Information

Surfaces

Physical: The cascade and cold plate surfaces are critical to good performance. Don't scratch them. Set them down on clean soft surfaces. Do not drag them or ding them. Don't drop things on them or gouge them.

Thermal: Tests have shown that plain surface to surface contact provides the best performance. This is true only when the surfaces are in excellent condition. Thermal interface materials can be used to compensate for damages at the loss of a little delta T. Factory installed units use an interface material.

Surface Prep

Don't forget to remove the clear plastic protective layer before use. If you've received an assembled system only the top plate will have plastic on it otherwise all critical surfaces should be protected.



If the surfaces have become damaged use a thermally conductive transfer medium. A thermally conductive pad is shown. Thermal transfer greases applied in a thin uniform layer work well but can be messy.



Cascade Installation

Step 1: If you haven't already done so, install the cover as shown earlier.

Step 2: If the cascade was not factory installed you'll have to do it . The following two pages show the mechanics of how.

Step 3: Next the power and sensor leads need to be routed through the hole provided in the hinge of the cover. The connector will have to be removed from the sensor leads first. From the rear use a slotted screwdriver to remove the set screw that fills the hole. Then guide the power and sensor leads through the hole.

Step 4: Rewire the sensor connector and plug into the back of the cold plate. Adjust the switch to the EXT position. **IMPORTANT** The switch **MUST** be in the EXT position and the sensor from the cascade **MUST** be plugged in for safe operation. If you are using a different external sensor it must reflect the top plate temperature well enough to avoid extreme (very hot) conditions.

Step 5: Wire the cascade power leads to the terminal block on the back of the AHP-1200CPV. Red = Positive Black = Negative

Step 6: Confirm steps 1-5

Caution:

The plate surfaces on AHP-1200CPV and CCP-22 cascade are precision machined flat surfaces. Do not damage or scratch these surfaces. Ensure they remain clean and free of dust and any other particles.

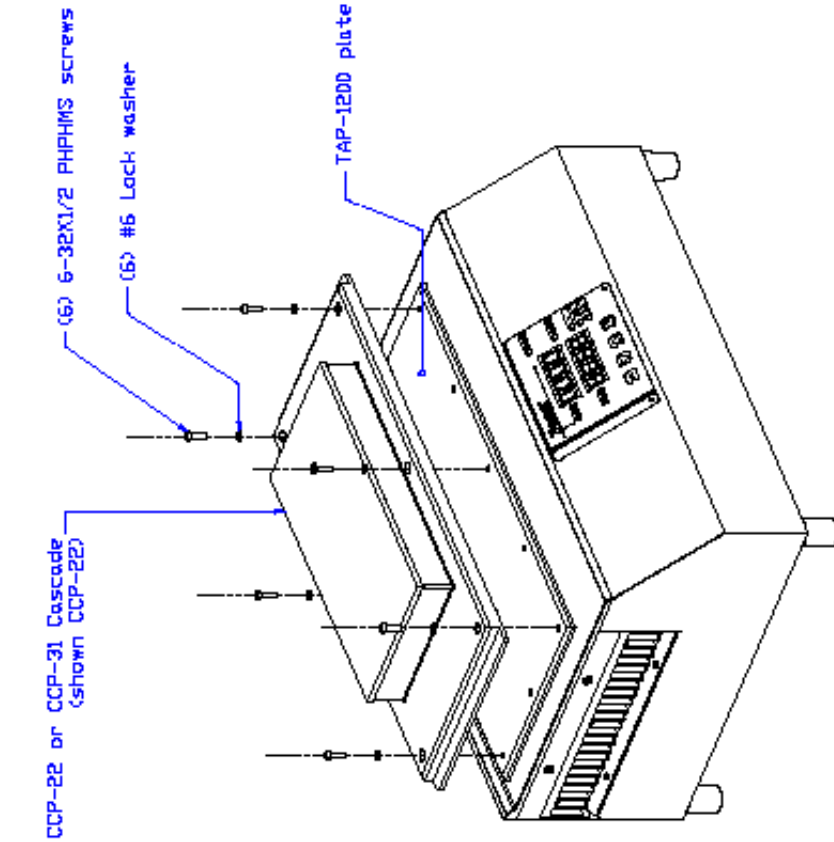

Installation of CCP-22 or CCP-31 via screws on AHP-1200CPV built with TAP-1200 plate

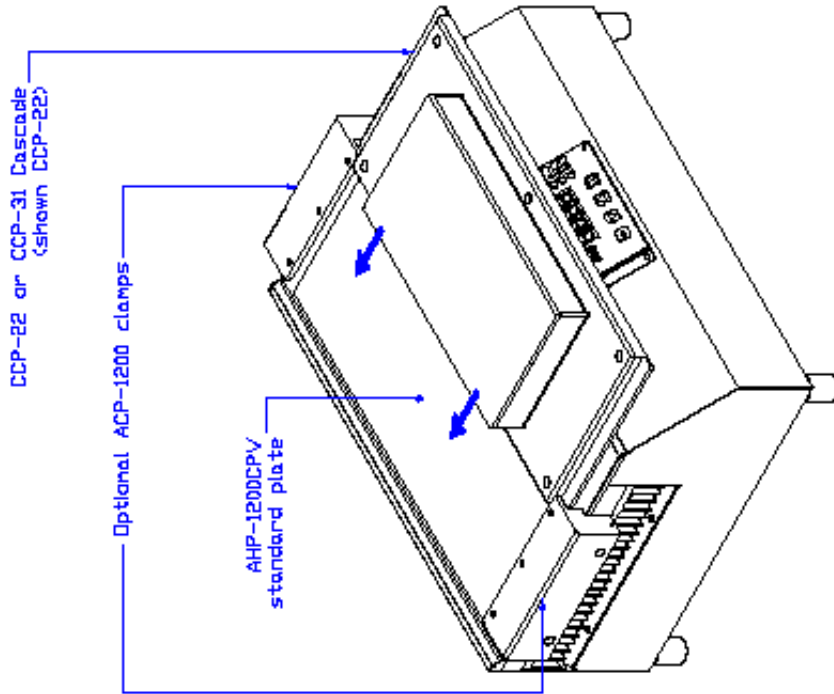

Installation of CCP-22 or CCP-31 via optional ACP-1200 clamps on AHP-1200CPV built with standard plate

INFORMATION DISCLOSED HEREIN IS THE CONFIDENTIAL PROPERTY OF TRICA CORP. RECEIPT SHALL NOT USE THE INFORMATION IN ANY UNAUTHORIZED MANNER. PRINTS

US: All Dimensions Indicated Unless Otherwise Indicated TOLERANCES ARE IN INCHES

DESIGNER	AA
CHECKED	AA
DATE	07/11/08
SCALE	1:1
DRAWING #	SK080710
NUMBER	SK080312
SHEET	08/01

TRICA CORPORATION 800 LINDEN AVENUE GAITHERSBURG, MD 20878

CCP-22 AND CCP-31
INSTALLATION ON AHP-1200CPV

REV	DESCRIPTION	DATE	APPROVED
-----	-------------	------	----------

Caution:

The plate surfaces on AHP-1200CPV and CCP-21 cascade are precision machined flat surfaces. Do not damage or scratch these surfaces. Ensure they remain clean and free of dust and any other particles.

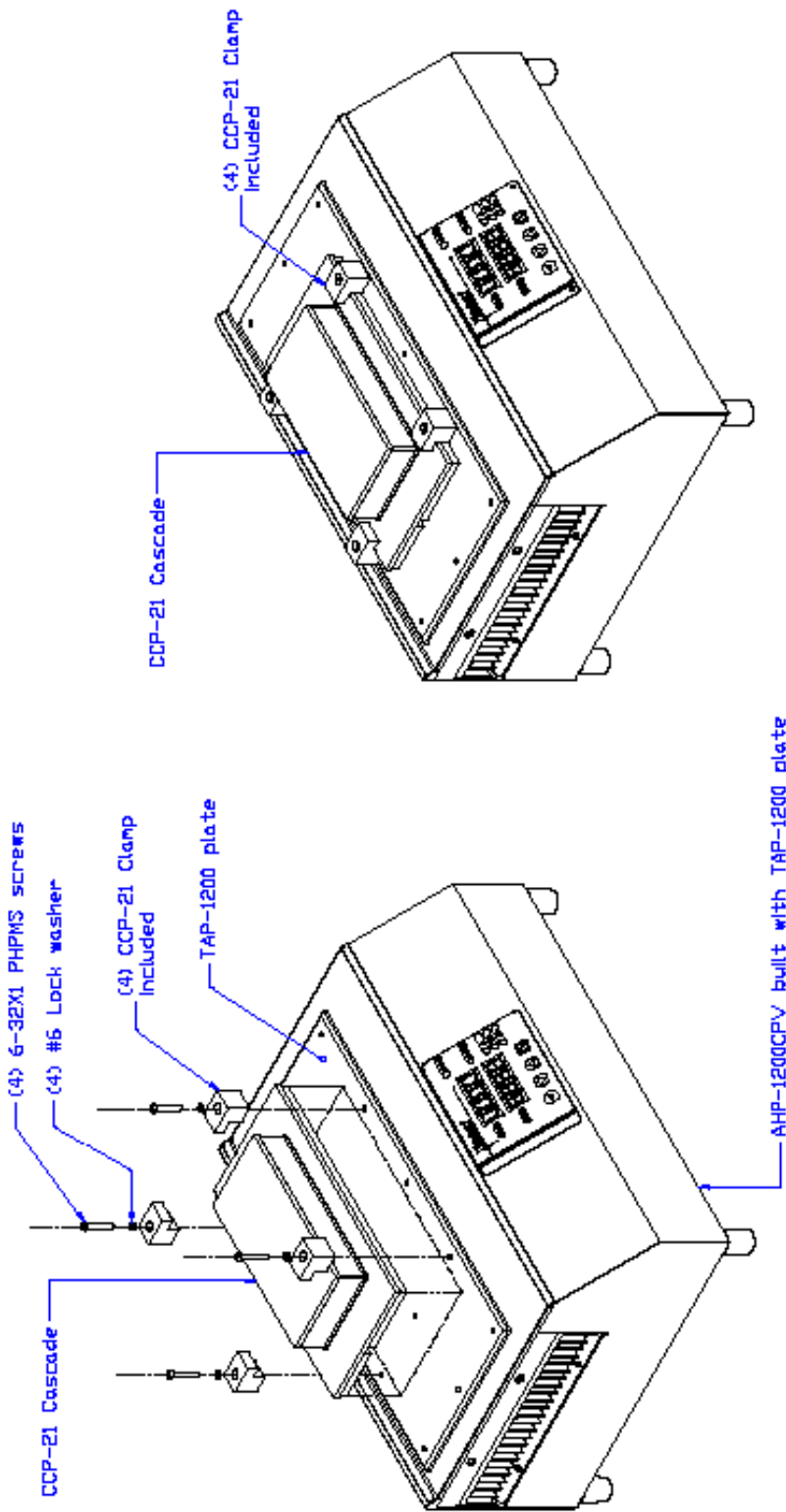

INFORMATION DISCLOSED HEREIN IS THE CONFIDENTIAL PROPERTY OF TERA CORP. RECEIPT SHALL NOT USE THE INFORMATION IN ANY UNAUTHORIZED MANNER. PARTS:	USE AND DISSEMINATION RESTRICTED. DIMENSIONS ARE IN INCHES. TOLERANCES ARE: DIMENSIONS IN PARENTHESIS ARE: FINISH: MATERIAL:	DATE: 07/14/08	DRAWN BY: AA	CHECKING # SK080712	SCALE: 1:1	PART NUMBER: SK080312	REV.	DESCRIPTION	DATE	APPROVED
							LEVEL	SHEET		

Safety Features and Standards

- Automatic recovery to set point after regain of power
- Program resume after regain of power
- Rear Condensate Guard
- Programmable over-temperature limits
- System shut down upon sensor break, over and under range
- NRTL evaluated to UL (Pending)
- NRTL evaluated to CSA (Pending)
- CE (Pending)

Warnings

- Read and understand the manuals included with the product.
- This product can get very COLD and very HOT. CAUTION should be used at all times. Do not touch any surface which may be at an extreme temperature range.
- ALWAYS assume the plate is too hot to touch.
- This product should be serviced by a qualified technician.
- Caution: Risk of electrical shock. Always disconnect the power when performing any servicing.
- Exercise every possible caution while cooling or heating all types of materials. Follow all precautions necessary for the particular material.
- Do not operate the cascade without a sensor installed such that it accurately reflects the plate temperature.
- Use the external sensor feature with caution. There may be a significant time delay between the cold plate temperature and the sensor temperature causing potentially dangerous overheat or freezing conditions.
- Use caution when controlling the plate to a temperature equal to the ambient. The hot side heat sink can become hot. If this condition occurs adjust the fan speed to 99% continuous.
- Operation of the cascade beyond its limit of 100 C is possible but not advised.
- Do not heat or stir volatile materials.
- This product is not explosion or spark proof.
- Do not immerse the unit for cleaning. Use soft non abrasive cleaners suitable for painted surface and anodized aluminum.
- Do not puncture or damage the black sealant.
- Route the power and sensor leads with caution. Condensation may well occur and it does run down these wires if not routed with care.
- Do not clamp material to the cascade using the accessory clamps or in a similar fashion.
- This product is for indoor use only
- Ambient temperatures from 1- to 40 C
- 100 to 240 VAC, 50/60 HZ operation, Fused for 800 watts max.
- Automatic recovery to set point after regain of power.
- Program will resume after regain of power.
- Programmable over-temperature limits.
- System shut down upon sensor break, over and under range.

How do I use it? NOW!

Step 1: Double check mounting and wiring. Make sure the cascade is in good contact with the cold plate and is wired to the rear terminals correctly. Check the sensor and the sensor switch for correct mounting and position.

Step 2: Locate the unit on a flat level surface like a bench. Make sure you have some room around it for good airflow.

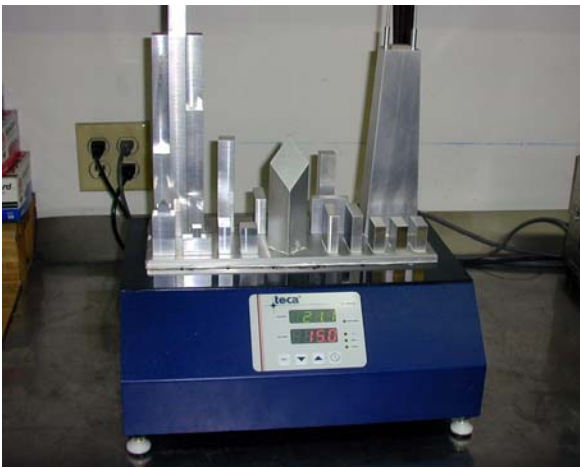

DO
Give it room to “Breath”

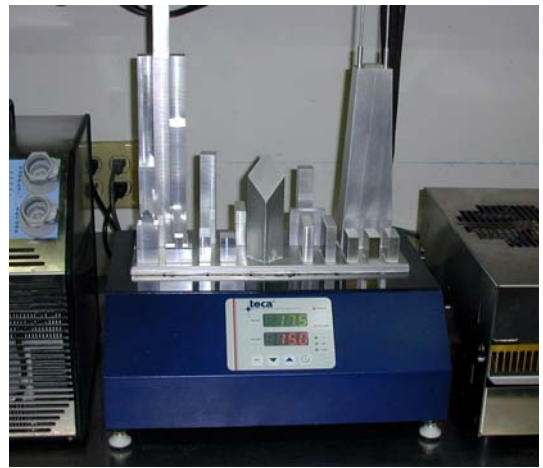

DON'T
Pile lots of stuff all around it.

Step 3: Plug the cord in the back of the unit, the other end in the wall outlet and turn the unit on. The temperature controller will turn on, the fan will start to spin and the plate will begin to approach the set temperature.



Step 4: Closely observe the operation of the unit.
Set the controller to -10. Carefully touch the plate or monitor it's temperature with a separate instrument to insure it's cooling.

If it feels as if it's getting cold continue watching as it approaches the set point. The fan should begin to quiet down as it slowly approaches the set point.

If it feels as if its getting cold but the process temperature is not changing the cascade sensor is not connected or is not installed properly.

If the sensor switch is on INT the unit will try to control the AHP-1200CPV plate and not the cascade top plate which will be uncontrolled and change in temperature erratically.

If it's feels like it's getting hot and the temperature on the display is rising the cascade is wired with the incorrect polarity.

If it's struggling to get to temperature seeming not to want to make it yet the fan keeps changing speeds you are likely close to the performance limit or the fan gain is set to low. Increase the fan gain or change it to continuous to get the most performance from your system

Step 5: Now What? Now to add what you're cooling.



Put something on the cold plate and adjust the set point using the arrow keys.

Front Panel Layout

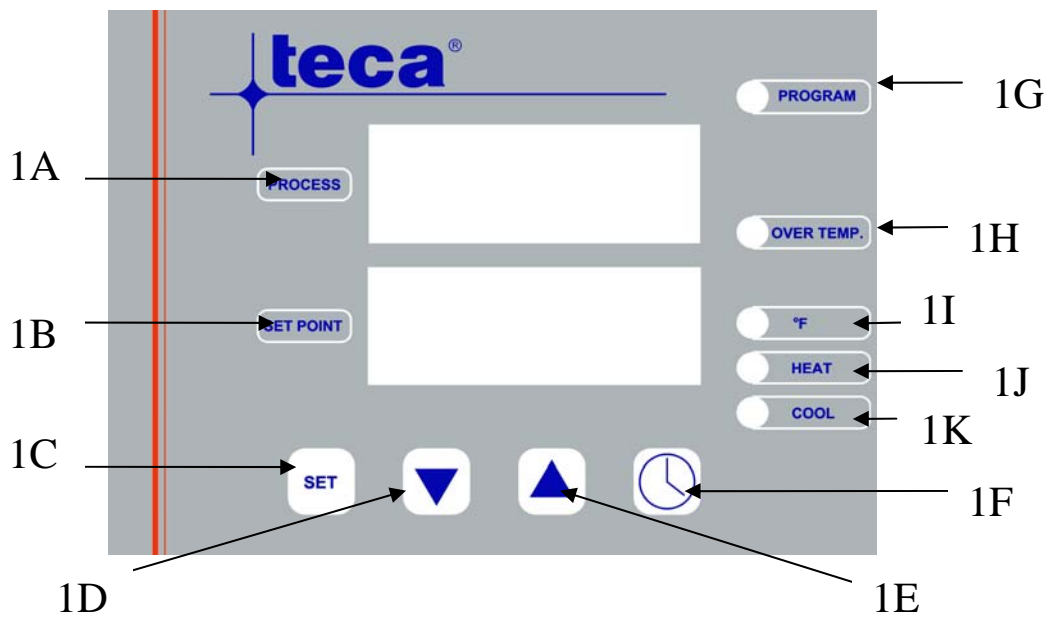

- 1A Process (Cold Plate) Temperature
- 1B Set Point Temperature
- 1C “Set” - Used in Programming
- 1D “Down Arrow” – Adjust Temperature down
- 1E “Up Arrow” - Adjust Temperature up
- 1F “Clock Symbol” – Used for programming and initiating program
- 1G This yellow light is ON when running a program
- 1H This red light will be ON during an overheat condition and flash after recovery until manually reset.
- 1I This light is ON when the controller is displaying degrees F.
- 1J This light is ON when heating.
- 1K This light is ON when cooling.

Physical Layout

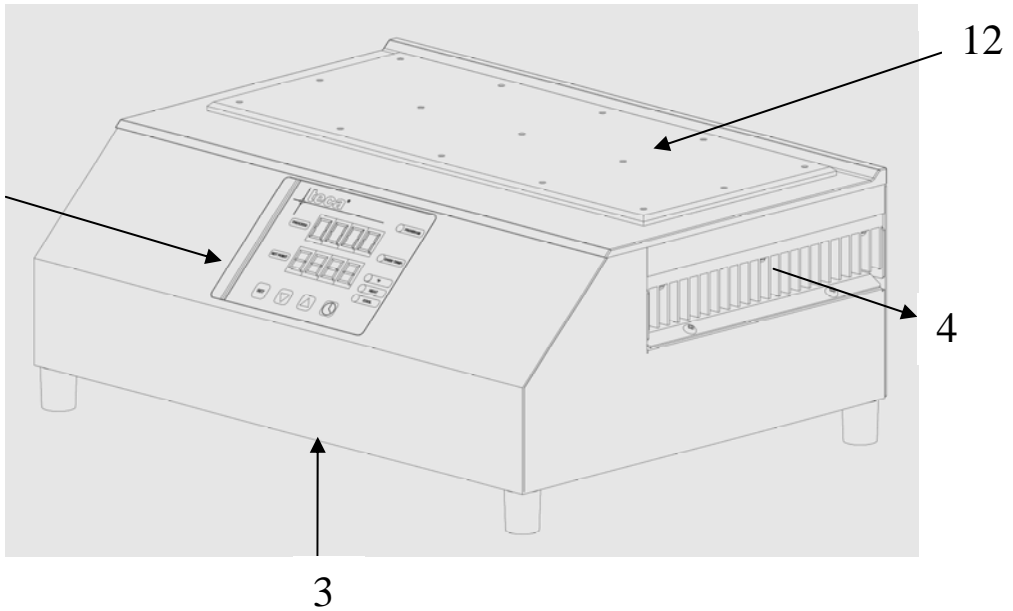
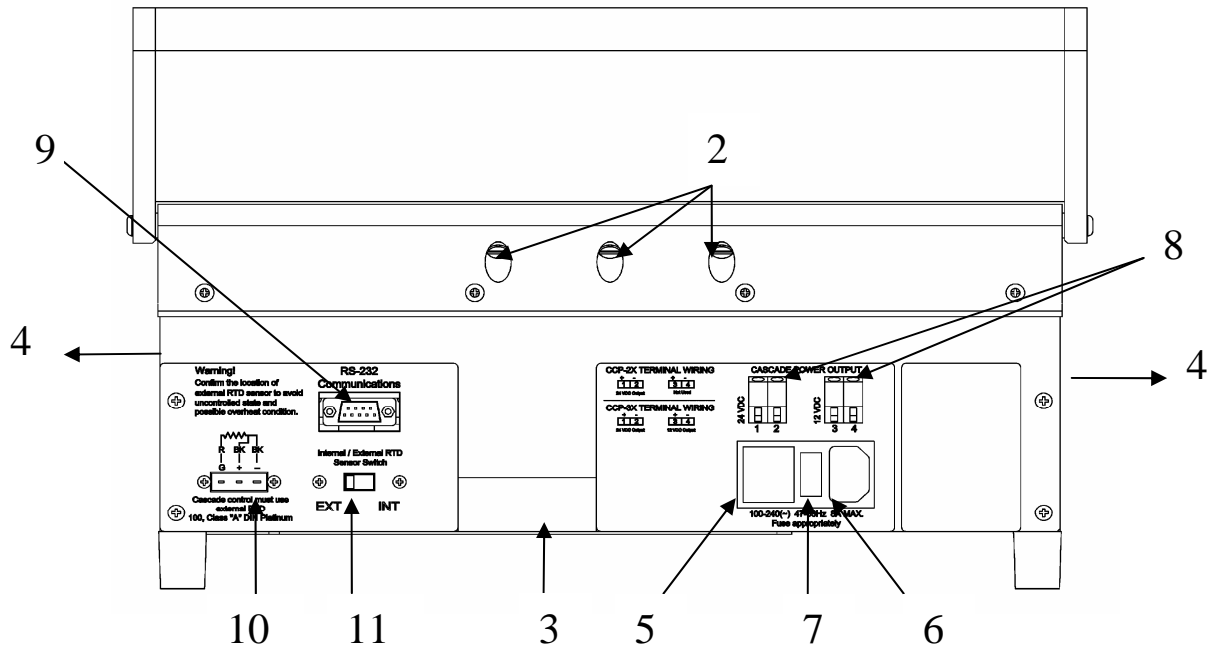

- | | | | |
|---|----------------|----|------------------------------------------|
| 1 | Front Panel | 7 | Fuse (5 x 20 mm, slow, 120 VAC, 6.3 amp) |
| 2 | Lead Pass Thru | 8 | Cascade Input Strip |
| 3 | Air Intake | 9 | RS-232 Port |
| 4 | Air Exhaust | 10 | External RTD sensor connector |
| 5 | On-Off Switch | 11 | Internal/external RTD Switch |
| 6 | AC Input | 12 | Cold Plate Surface |

Adjusting the Set Point Temperature

The Set Point is adjusted by pressing the up or down arrow keys.

Initiating the Auto Tune function

The Auto Tune function adjusts specific control parameters to provide good control at the specific set point based upon the reaction of the system to the cooling device. These parameters will be different for different systems and for different circumstances within the same system. These circumstances include changing set point and load.

To set the Auto Tune press the “set” button then use the arrow keys to set the process to “on”. The set point should say “OPt”. Press the “set” button again. Wait for the display to clear, about 5-10 seconds, and the temperatures to return in the display. The “process” display will alternately flash “OPt” and a temperature until the tuning process is complete.



Changing temperature indication from C to F

Change the P1 parameter in the configuration level, CnF from 7 to 15. See page 14 for instructions regarding Controller Modes.

Over Temperature Safety

The over temperature feature works for the cold plate of the CPV. It does not protect the upper cascade options from overheating

When an over temperature condition occurs the following will happen:

- The OVER TEMP light will be on.
- System heating and cooling will be disabled
- The pump reset function will be disabled
- If a program is running it will be placed in the “hold” mode

When the condition has cleared normal operation will resume. Heating and cooling will be enabled. The OVER TEMP light will flash until the over temperature condition has been acknowledged using the L.rS parameter in the Basic Mode.

.

Adaptive Fan Control

Adaptive Fan Control is a special feature designed to improve overall temperature control and user comfort while maintaining maximum performance when needed. The most evident characteristic is the reduced fan noise as the system approaches set point. The fan speed is directly related to the amount of cooling required. This feature has been factory preset. Changes, while not recommended, can be made within the “Set-Up Operator” mode described later in this manual. Detailed information is found in the TC-4300 Operators Manual.

Using the external RTD sensor

Cascade products have an RTD built into their top plate. This in turn is connected to the rear panel as an “external RTD” even though it’s built in. Take care to make sure the connector is wired properly. Make sure the switch is in the EXT position.

Caution!! Use the external sensor feature with caution. There may be a large time delay between the plate and the sensor temperatures causing overheating and under-cooling conditions. Fully evaluate the system conditions prior to and during the use of this feature. The RTD is a three wire, 100 ohm, single element, Class A. Make sure that the external sensor reflects the plate temperature to avoid extreme (HOT !) conditions.

Identify where and how you wish to use the external sensor. Take special consideration and thought with respect to system safety.



Connect the sensor to the back of the chiller, slide the selector switch to the EXT setting, turn the unit on and verify the function and safety.

A faulty or disconnected RTD is signaled on the display as %%% %h

Guaranteed Soak and Ramp Tracking Limits



For the Guaranteed Soak Limit function enter the configuration level, CnF and change the P46 parameter to anywhere from 0.1 to 100.0 degrees C or F. Example: SP=70, P46=2.5, the program waits when PV>72.5 or PV<67.5. Setting to OFF will disable this function.

Parameters P44 and P45 respectively set the Low and High Tracking limits. Setting to OFF disables these functions.



Controller Modes

Warning: There are many parameters which can be changed in each mode. Those used in normal day to day operation have been described in previous sections. Do not make changes to any parameters unless it is covered in this manual. Other changes may alter the function of the system in an inappropriate and/or unsafe manner.

Mode	Code	Description
Basic Operator	OP.b	From this level an operator can change set point, force an auto tuning process, start a predefined program, and reset the pump.
Program Editing	OP.P	In this level individual program segments are defined, as well as the number of program cycles.
Set Up Operator	OP.S	From this level an operator can set PID parameters, set point limits, and other key operational parameters. Use with caution.
Configuration	CnF	This is the level for factory configuration.
Input Calibration	I.CL	This is the level for access calibration parameters.

* To switch controller modes, press the  and **SET** pushbuttons for more than 3 s. The display will soon show OPr and the current operational mode. Press the  or  pushbutton to select the new level.

*To confirm the selection press the **SET** pushbutton.

*OP.S (1), OP.P(415), and CnF each have their own pass code for level access. If the selection is other than OP.b The display will show display PASS and ---- . Press the  or  pushbutton to set the proper password. **Passwords:** OP.S – 1 OP.P – 2 A.CL, CnF, I.CL – 415 Press **SET** to confirm.

*To inspect or modify parameters press **SET** key. To modify a selection use the  or  buttons. Press **SET** again to store the new value and to advance to the next parameter.

*Push  to scroll backwards through parameters without storing them.

*If no button is pushed for 10 seconds the normal display will appear without modifying the last parameter

Basic Operator Mode (Normal, day to day operation)



To change the set point:

- Press ▼ or ▲ pushbutton for more than 1.5 s to begin modifying the set point.
- Continue until the desired set point has been reached.
- The new set point will be loaded automatically after a 2 second delay.
- By pressing  or **SET** it is possible to abort the modification..

To begin control optimization:

- Change the setpoint to the desired temperature
- Press **SET** to view and scroll thru the parameters in the lower display until you find Opt.
- Press ▼ or ▲ to change the Off in the top screen to On
- Press **SET** again to store the new value.
- The display will return to normal in 5 to 10 seconds.
- During the optimization process the upper display will alternate between the actual process temperature and Opt.
- The display will return to normal when the control optimization process is complete.

To begin the Ramp/Soak Program:

- Press **SET** to view and scroll thru the parameters in the lower display until you find nPRg. Select the program you wish to run and press **SET**
- Press the  button on the front panel for 2 – 3 seconds to start the ramp soak program
- Press the  button on the front panel for 2 – 3 seconds to stop the ramp soak program

Programming Mode

The Basics:

- There are 32 segments available in 4 programs of 8 segments, 2 programs of 16 segments, 1 program of 32 segments
- Set Points - What temperature do you want to get to? Initial set points are required for every program. Target set points are required for every segment.
- Actions are required for each segment
- Ramp Rates - How fast would you like to get there?
- Dwell Times – How long do you want to stay there?
- Programming can be done from the front panel or software

The Software:

- TECA EZLog is a software package which helps you to build ramp soak programs, set temperatures, tune to set point, view & record data.
- iTools Engineering Studio from Eurotherm is a much more complex software for making many more changes to the temperature controller than just the ramp/soak programs. Only the experienced should work with this. Usually there is no need to do so. Changing the wrong parameter can cause system failure which is not covered under the warranty. Use with caution.
- Eurotherm iTools OPC Server optional, not included (for connection to Labview, etc)

The Manual Method:

- The specific definitions for each segment parameter are shown in the following pages.
- Each segment is identified by a number.
- To select a program to edit, modify the nPrg parameter in the basic mode.
- Then access the “Program edit operative mode” to address each parameter of each segment in order.

Example Profile

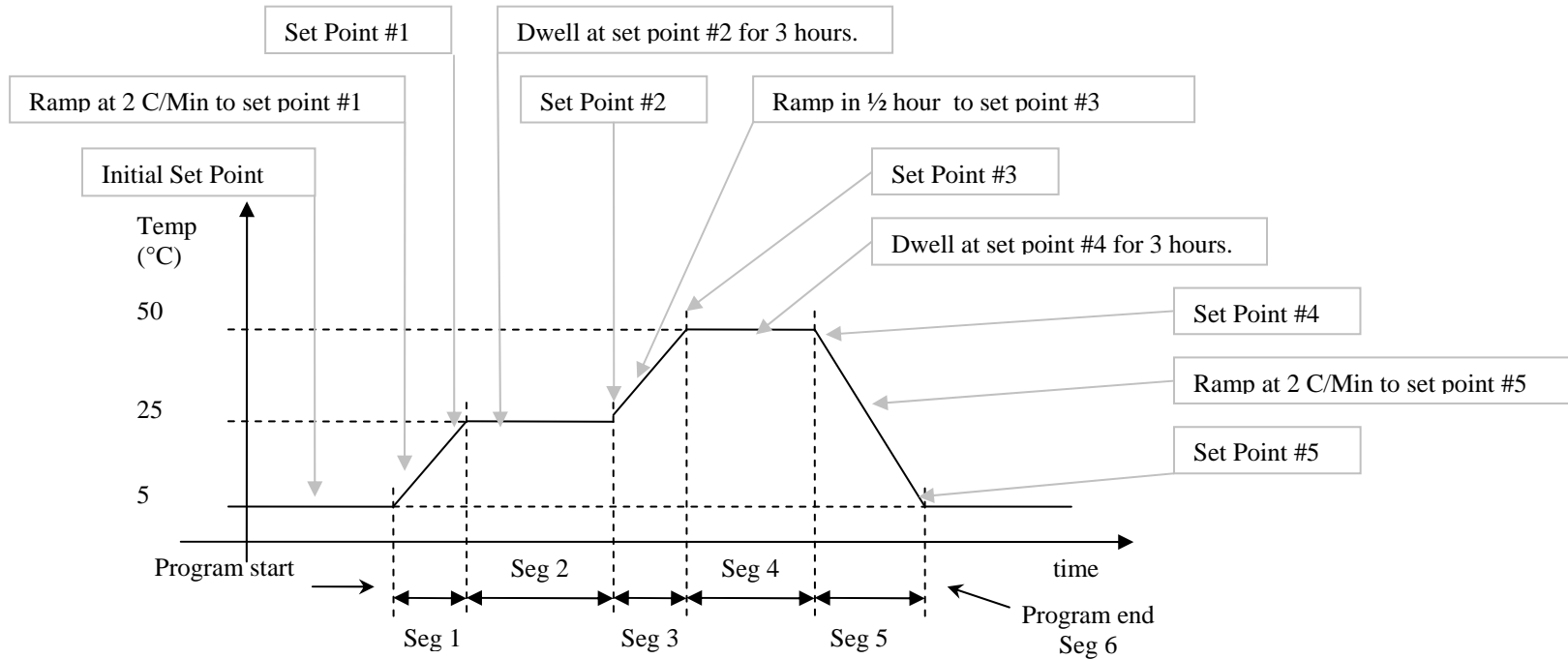

Segment			Target Set Point		Temperature	Action				Elapsed
Symbol	Description	Value	Symbol	Description	(°C)	Symbol	Description	Value	Units	Time
			itSp	Initial Set Point	5		dwell			
Seg	Segment #	1	Sp. 1	Set Point 1	25	rr. 1	Ramp at a defined rate	2	C/min	0.5
Seg	Segment #	2	Sp. 2	Set Point 2	25	rH. 2	Dwell for defined time	3	Hours: minutes	3
Seg	Segment #	3	Sp. 3	Set Point 3	50	TH. 3	Ramp in defined time	0.5	hours	0.5
Seg	Segment #	4	Sp. 4	Set Point 4	50	TH. 4	Dwell for defined time	3	Hours: minutes	3
Seg	Segment #	5	Sp. 5	Set Point 5	5	rr. 5	Ramp at a defined rate	2	C/min	1.4
Seg	Segment #	6	Sp. 6	Set Point 6	END					

Symbols and Definitions				
Parameter	Meaning	Range	Available	Alterable
nPrg	number of the selected program	from 1 to 4	always available	only when the programmer state is idle
Seg	number of the segment in execution	from 1 to 8	only when the programmer state is run or hold	never
rt.	remaining time to the end of the program This value refers to the time remaining to the end of the current execution, regardless the programmed number of executions	- from 1 second to 99 min 59 sec the upper display shows 12.30 (12 min 30 sec) the lower display shows rt.S - from 1 h 40 min to 99 h 59 min the upper display shows 18.45 (18 h 45 min) the lower display shows rt.H - from 100 to 9999 hours the upper display shows 125 (125 h) the lower display shows rt.H - over 9999 hours the upper display shows %%%% the lower display shows rt.H	only when the programmer state is run or hold	never
r.rpt	remaining repetitions before the end of the program	- from 0 to 9999 and then inF The figure shows the remaining repetitions after the current execution. For example 0 means that the program stops at the end of the current execution, while inF means that the device is set for endless repetitions.	only when the programmer state is run or hold and the "Program execution repetitions" parameter is different from 0	Never
Rpt	time remaining to the end of the program, considering also the remaining repetitions	- from 1 second to 99 min 59 sec: the upper display shows 12.30 (12 min 30 sec) the lower display shows rpt.S - from 1 h 40 min to 99 h 59 min the upper display shows 18.45 (18 h 45 min) the lower display shows rpt.H - from 100 to 9999 hours the upper display shows 125 (125 h) the lower display shows rpt.H - over 9999 hours the upper display shows %%%% the lower display shows rpt.H	only when the programmer state is run or hold and the "Program execution repetitions" parameter is different from 0	Never
itSp	setpoint is the setpoint used by the programmer during the "idle" state.	OFF, and then from rL (setpoint low limit) to rH (setpoint high limit) If set to OFF control outputs will be disabled during the "idle" state. At a program start, the setpoint will be aligned to measure value and then ramp to SP. 1.	always	only when the programmer state is idle
Sp.1	target setpoint of the first segment. This parameter is used also to select the segment type: - setting it equal to the previous setpoint creates a dwell segment	from rL (setpoint low limit) to rH (setpoint high limit)	always	only when the programmer state is idle
t. 1 or rr. 1	duration or ramp rate of the first segment	from 1 sec to 99 min 59 sec (the lower display shows t.s. 1) from 1 min to 99 h 59 min (the lower display shows t.H 1) from 0.1 to 3000 engineering units (°C or °F) per minute (the lower display shows rr. 1) Use the up or down arrow buton to select the desired value within the current range. To change the range, travel to the high or low limit, release and press again the up or down key. The lower display will change to point out the next or previous available range.	always	only when the programmer state is idle
Sp.2	target set point of the second segment. This parameter is also used to select the segment type: - setting it equal to the previous setpoint creates a dwell segment - setting it different from the previous setpoint creates a ramp segment	End, and then from rL (set point low limit) to rH (set point high limit) The End value, selectable from the second to the seventh set point, is used to end the program before the last segment.	always	only when the programmer state is idle
Rpt	number of program repetitions of the selected program	- from 0 to 9999 and then inF The figure expresses the repetitions after the first execution. Example: If 2 is selected, the program will be executed 3 times, while inF means that the device is set for endless reps.	always	only when the programmer state is idle

Then t. 2 (or rr. 2), Sp. 3, t. 3 (or rr. 3), ... , Sp. 8, t. 8 (or rr. 8) as above.

